

YAKOVLEV YAK-9

BY TIMO STARKLOFF

PLAN No: RC2219 | No. OF SHEETS: 1 OF 2 | First published in RCM&E May 2020

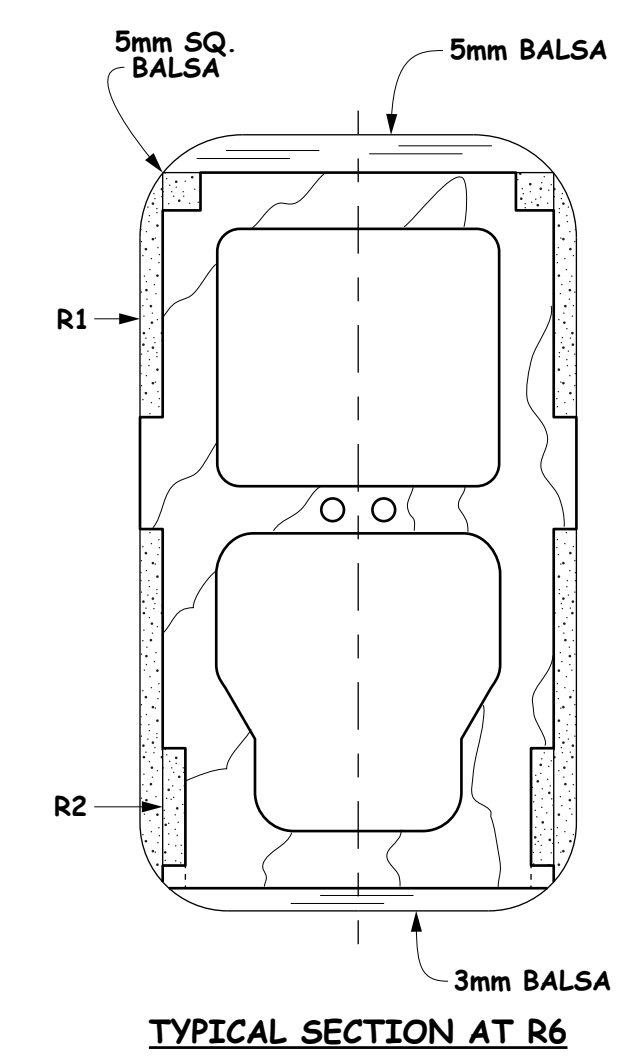
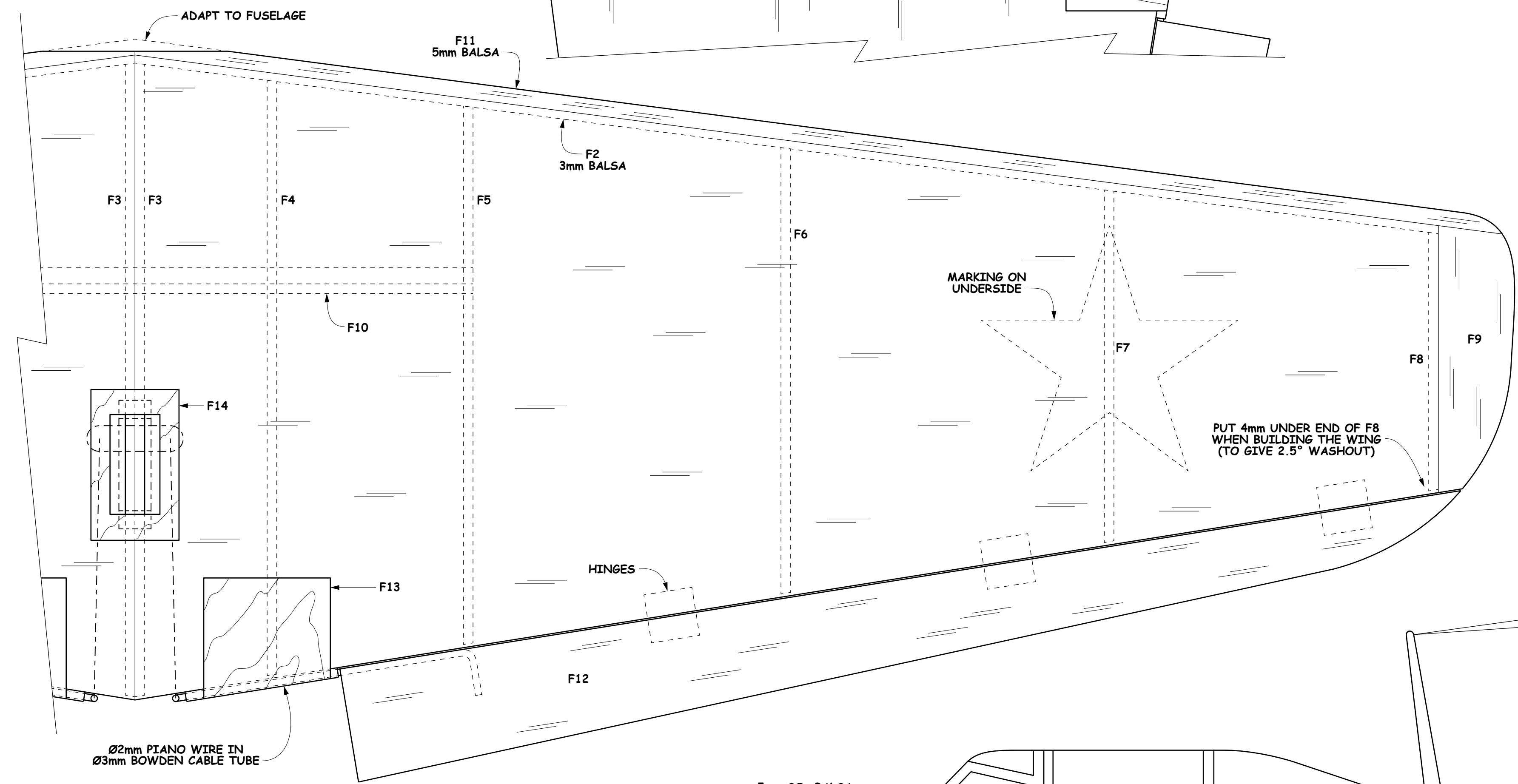
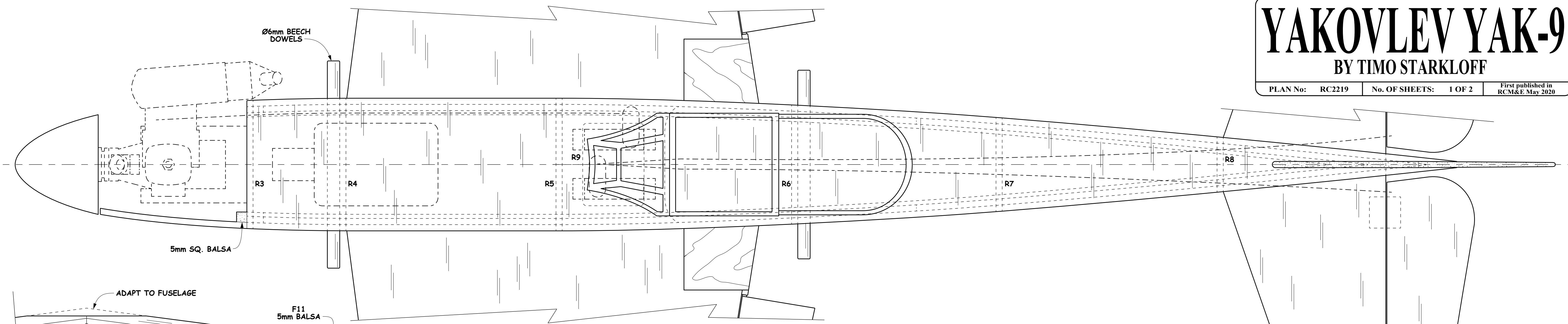

CONTROL MOVEMENTS:
ELEVATOR: +6mm, -5mm
AILERONS: ±5mm

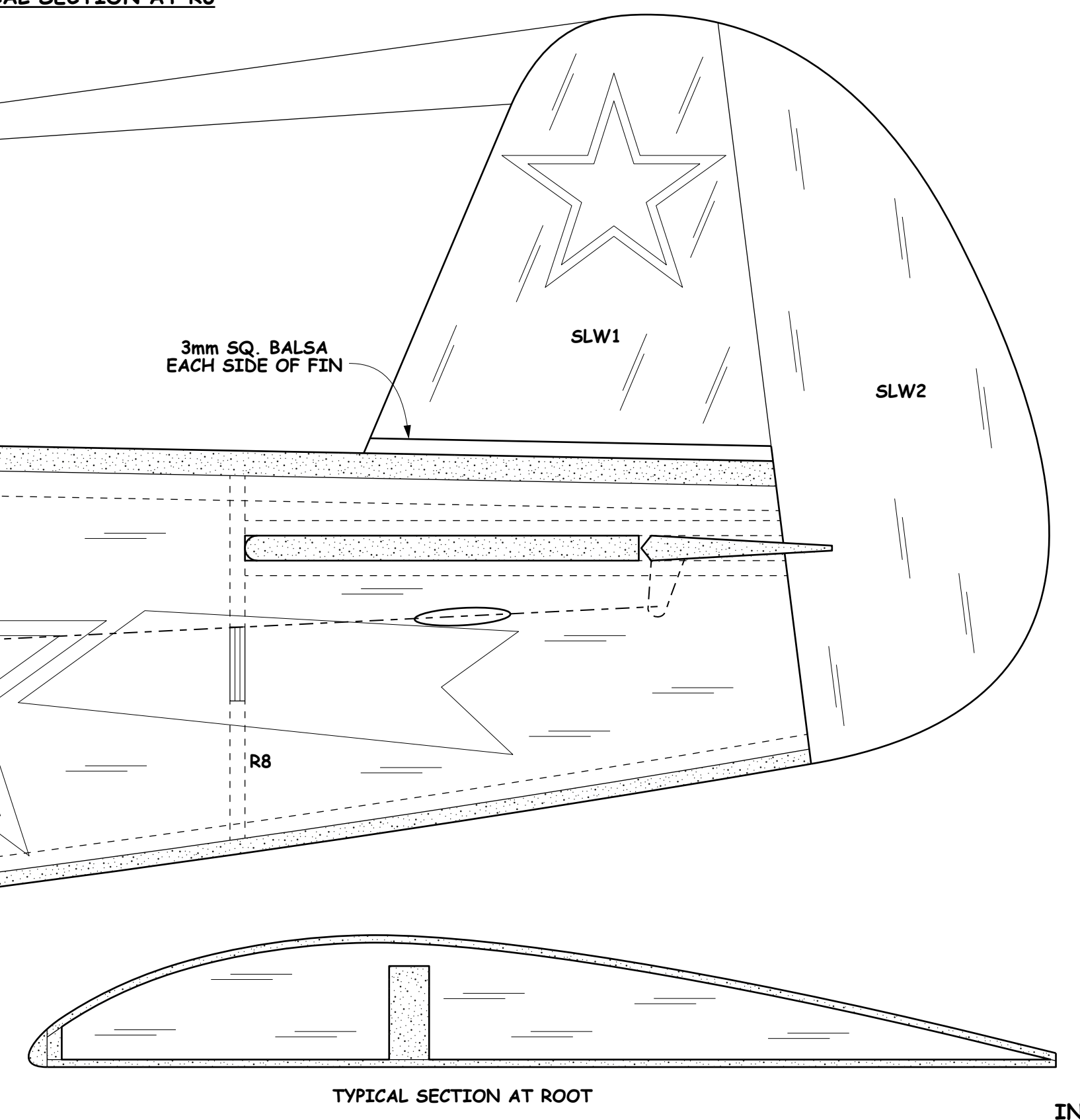
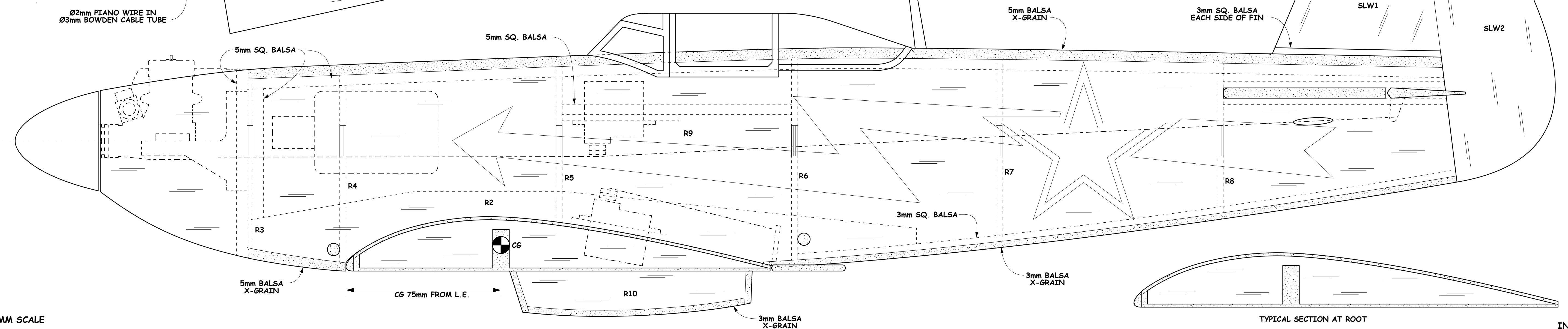

MM SCALE

IN. SCALE